



Groundwater Flow Analysis



Aquifer parameters

- An aquifer is a geological unit capable of yielding useful groundwater supplies to wells and springs
- Aquifer requirements:
 - stores useful amounts of water => storativity
 - allows reasonable flow rate => transmissivity
 - is replenished => recharge

Aquifer pre-requisites

- **Stores useful amounts of water**
 - **Storativity**
- Allows reasonable flow rate
 - Transmissivity
- Is replenished
 - Recharge

Storage (Storativity)

- Unconfined aquifer
 - Storativity related to effective porosity
- Confined aquifer
 - Storativity related to specific storage (compressibility of aquifer formation)

Unconfined conditions

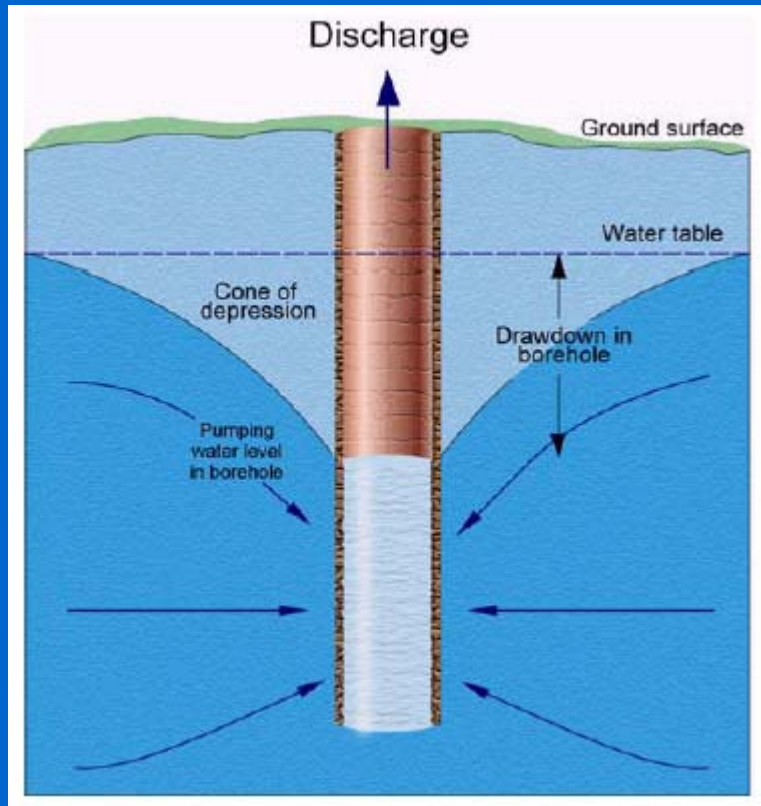

Falling water table causes drainage from the pore space, so

Storage related to effective porosity

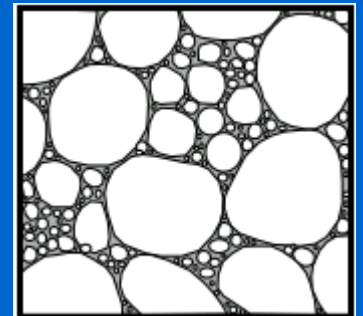

Confined conditions

Unit remains saturated, storage related to compressibility

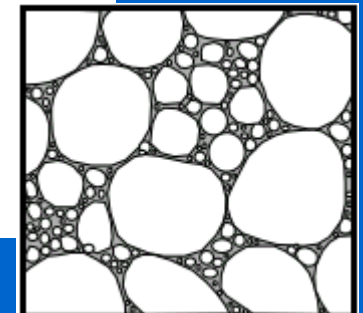
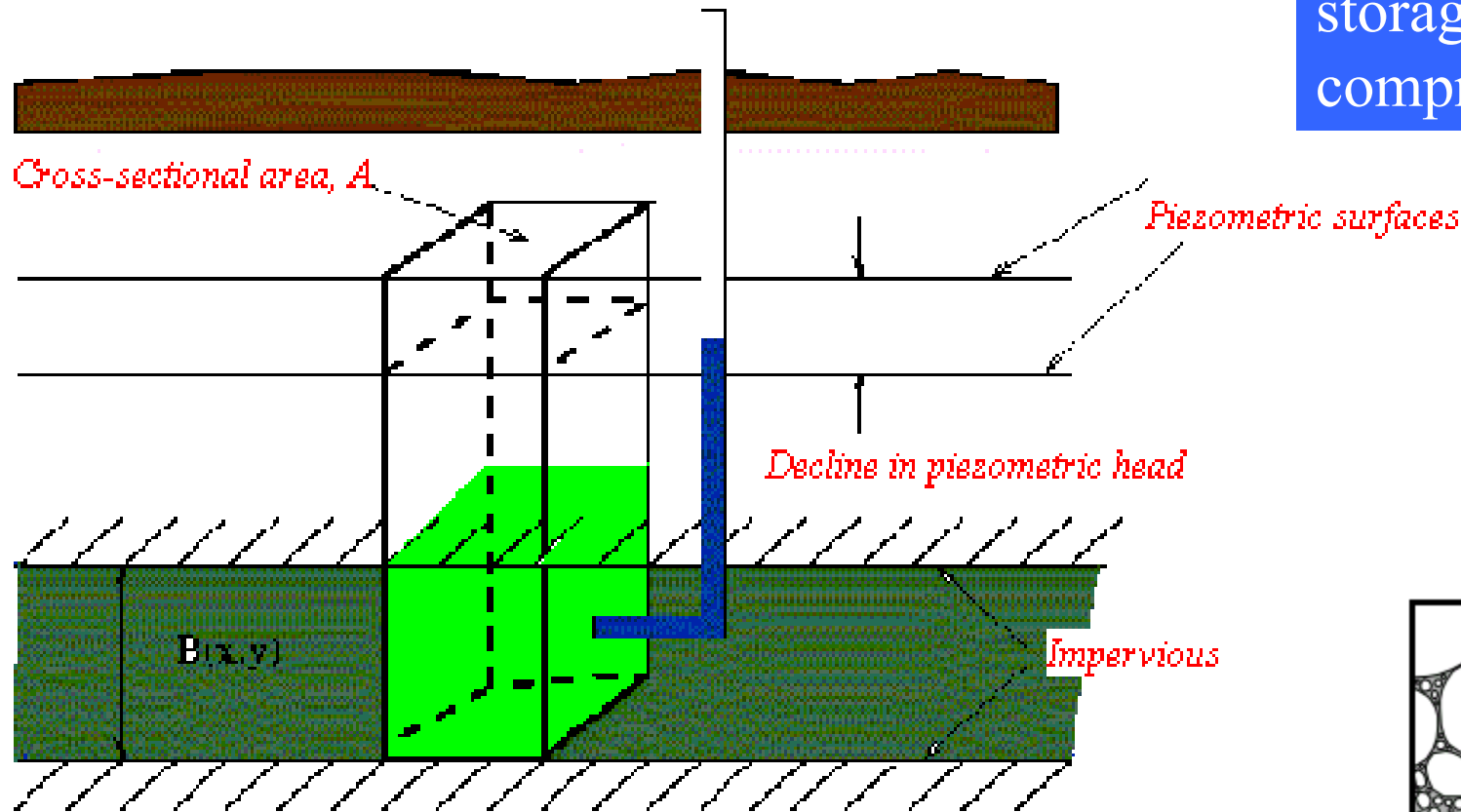

Aquifer pre-requisites

- Stores useful amounts of water
 - Storativity
- **Allows reasonable flow rate**
 - **Transmissivity**
- Is replenished
 - Recharge

Transmissivity

- A measure of how easily water is able to flow through the aquifer, a function of:
 - Hydraulic conductivity (permeability), and
 - Aquifer thickness

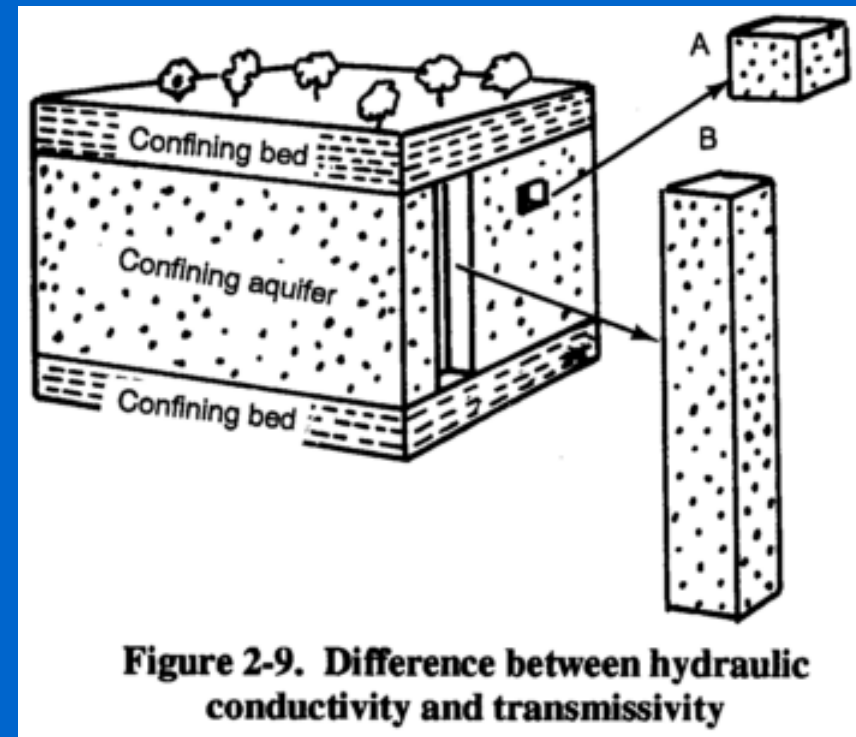

Unconfined vs. confined

- Unconfined aquifer
 - saturated thickness changes when water table moves,
 - Transmissivity is variable

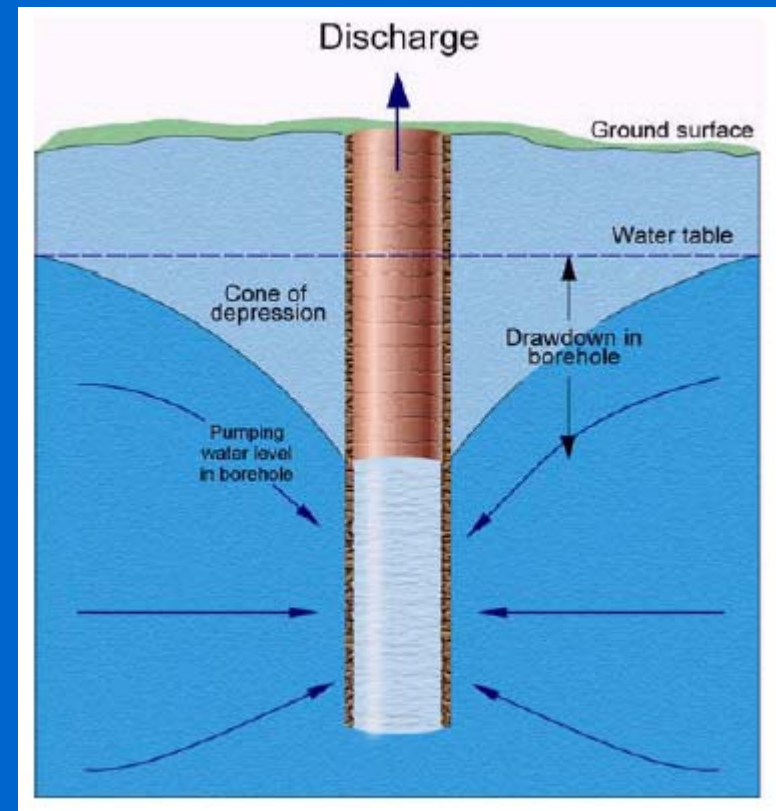

Unconfined vs. confined

- Confined aquifer
 - saturated thickness is unchanged by change in piezometric surface
 - Transmissivity is constant

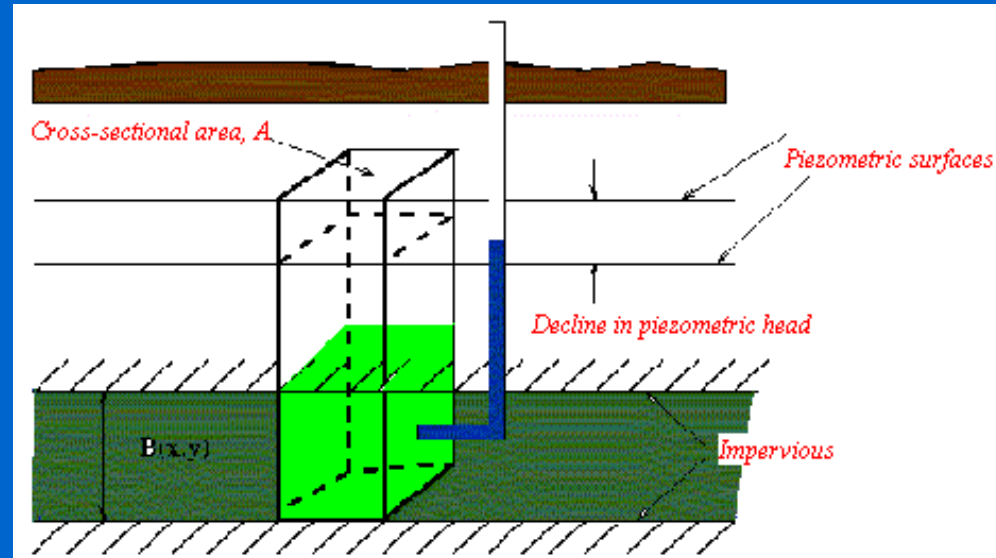

Aquifer pre-requisites

- Stores useful amounts of water
 - Storativity
- Allows reasonable flow rate
 - Transmissivity
- **Is replenished**
 - **Recharge**

Recharge

- Largely dependent on rainfall
 - Water level declines are unlikely to increase recharge rate
- Sometimes contributed by rivers
 - Water level declines may induce additional inflows from rivers and reduce outflows to groundwater dependent streams (stream depletion).

Other boundaries

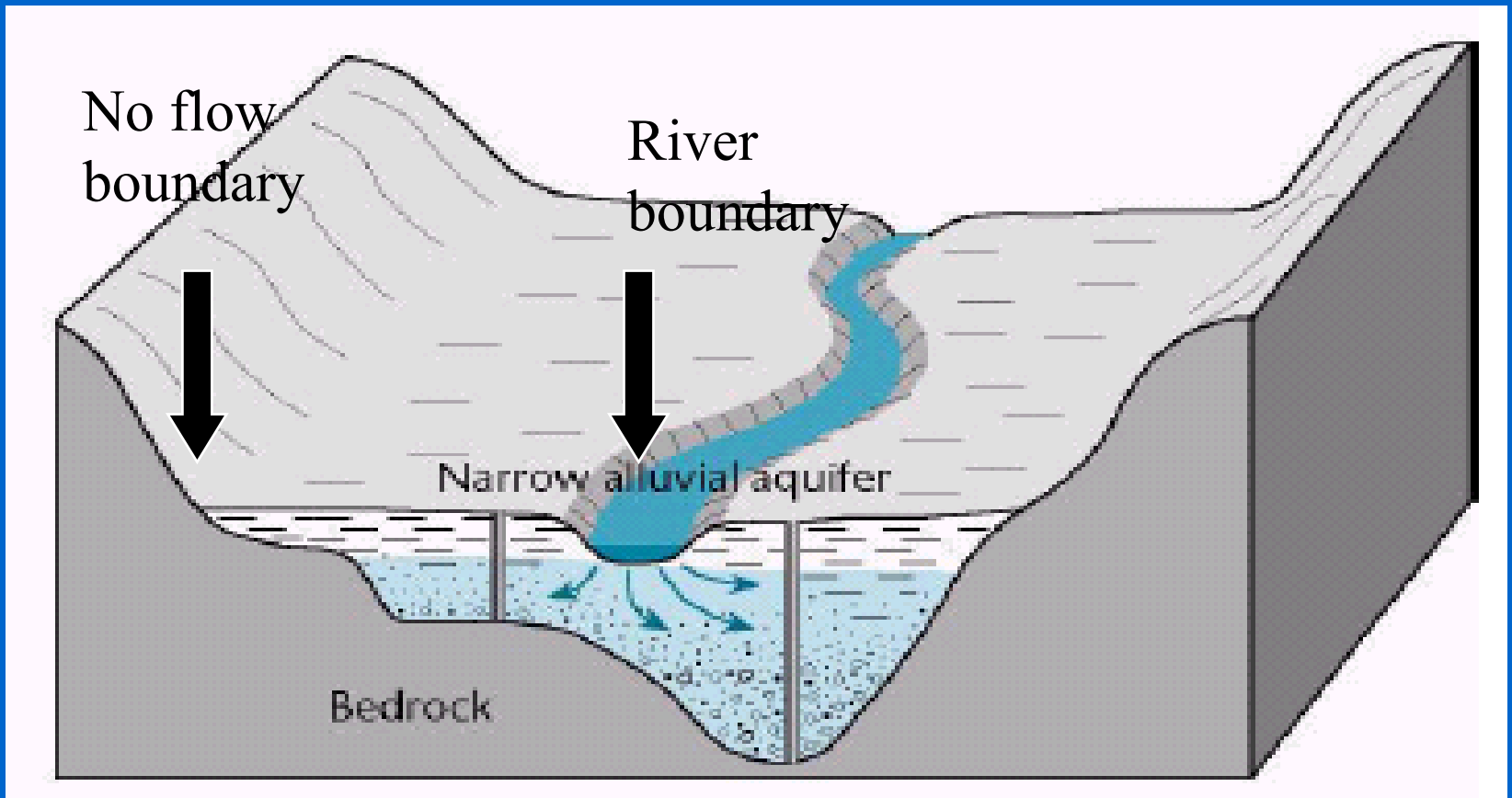

Fresh/saline interface

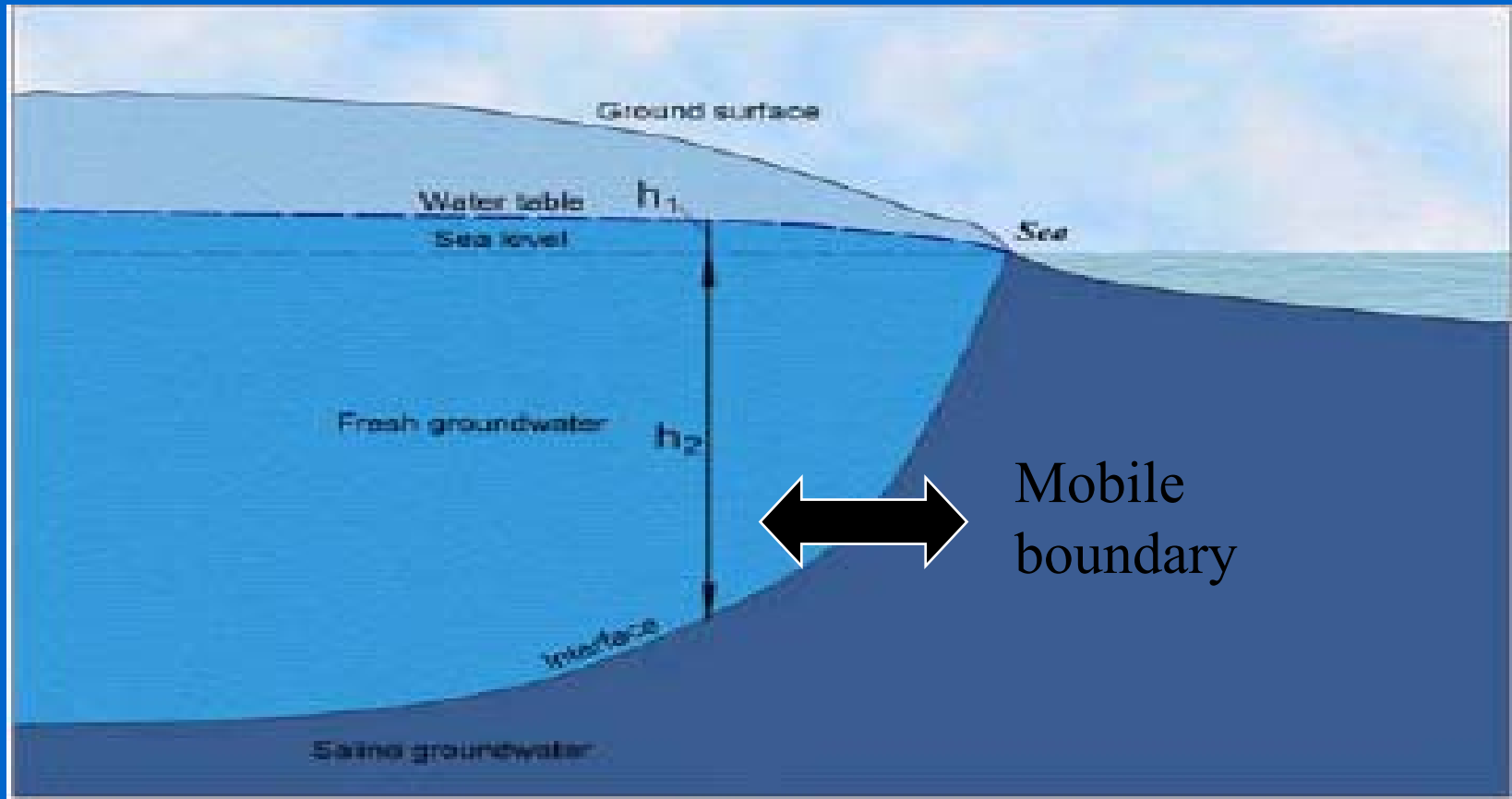

Darcy's Law

- “Newton's Law” for groundwater
- $Q = KA (h_1 - h_2) / L$
 - Q is discharge
 - K is hydraulic conductivity (permeability)
 - A is cross-section area
 - h_1 and h_2 are piezometric head, at distance L

$$Q = KA (h_1 - h_2) / L$$

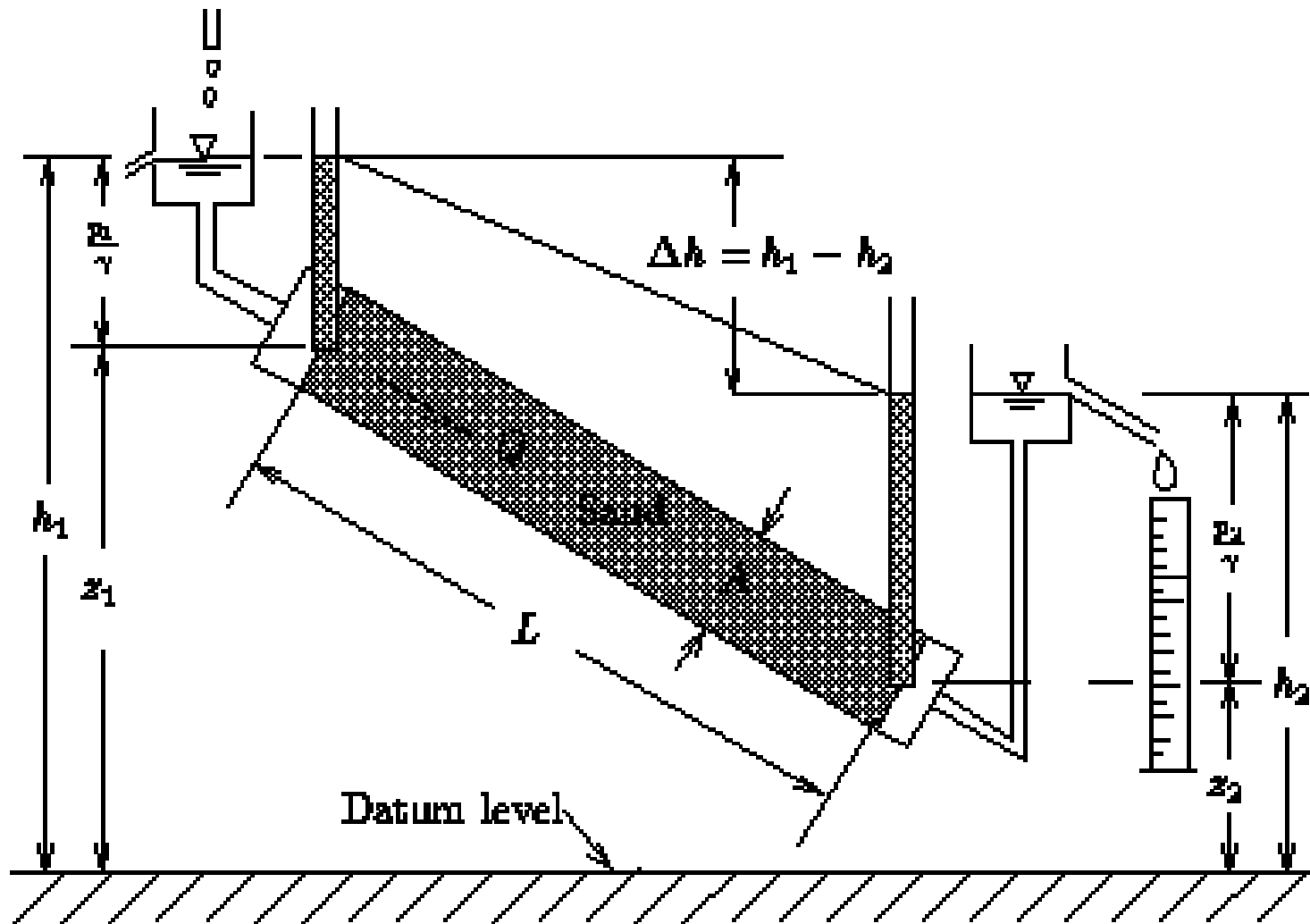

Representative values of K (m/d)

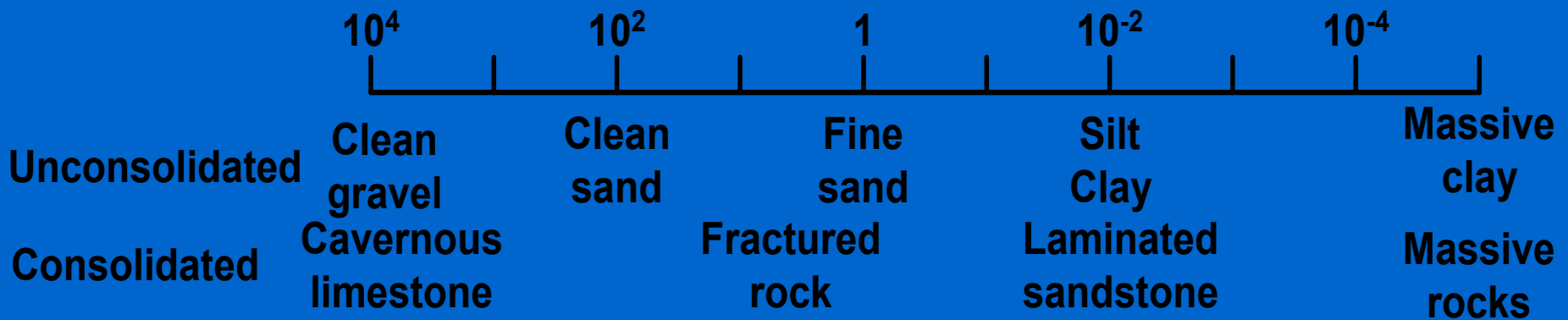

A simple model

- Drawdown response to pumping in an extensive confined aquifer

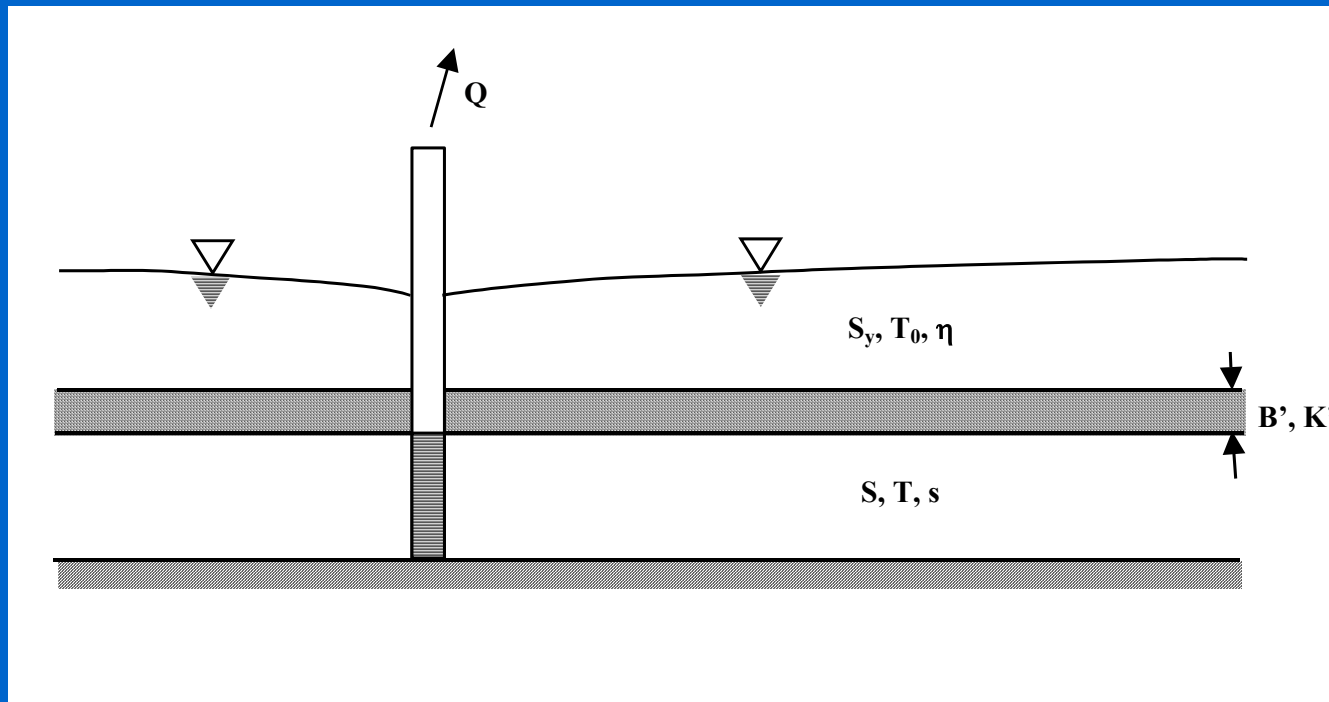

The Theis solution

Assumptions:

Infinite extent, homogeneous, fully confined

$$s = \frac{Q}{4\pi T} W(u)$$
$$u = \frac{r^2 S}{4Tt}$$

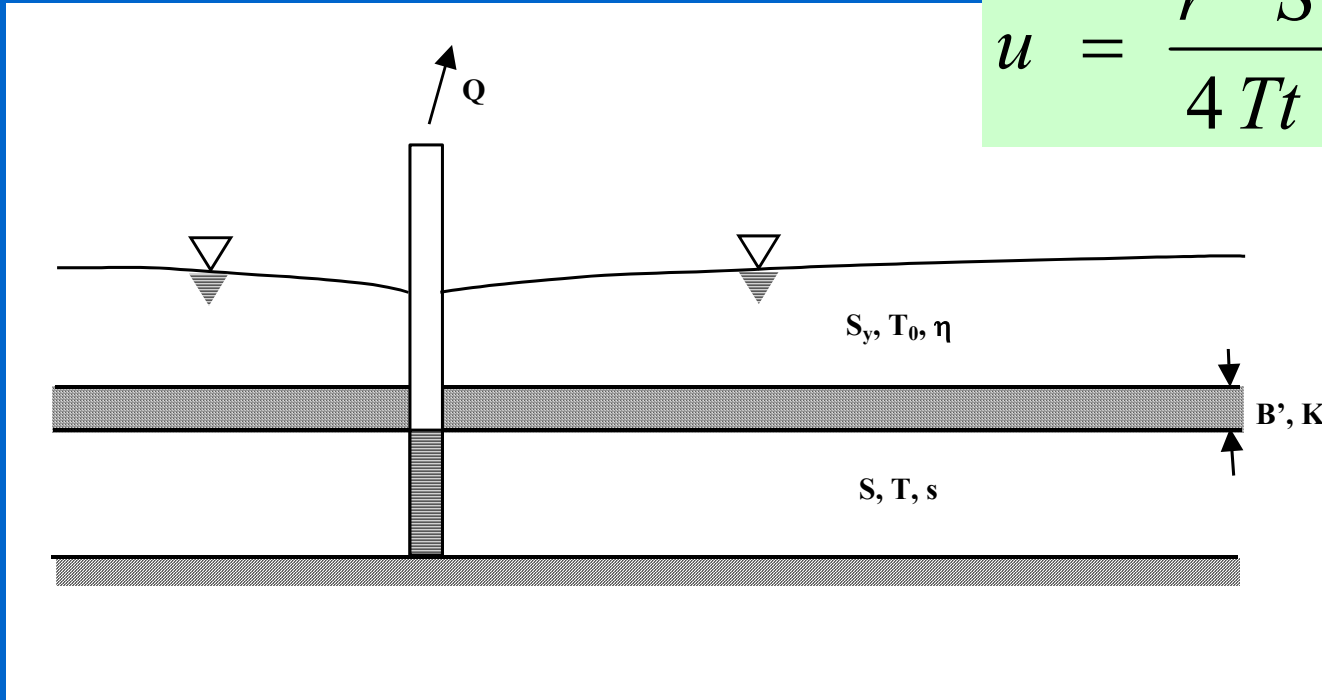

Simple Excel model

- This solution for drawdown response to pumping:

Examine effect of changing:

- transmissivity (T)
- Storativity (S) unconfined & confined

Using functions in Excel

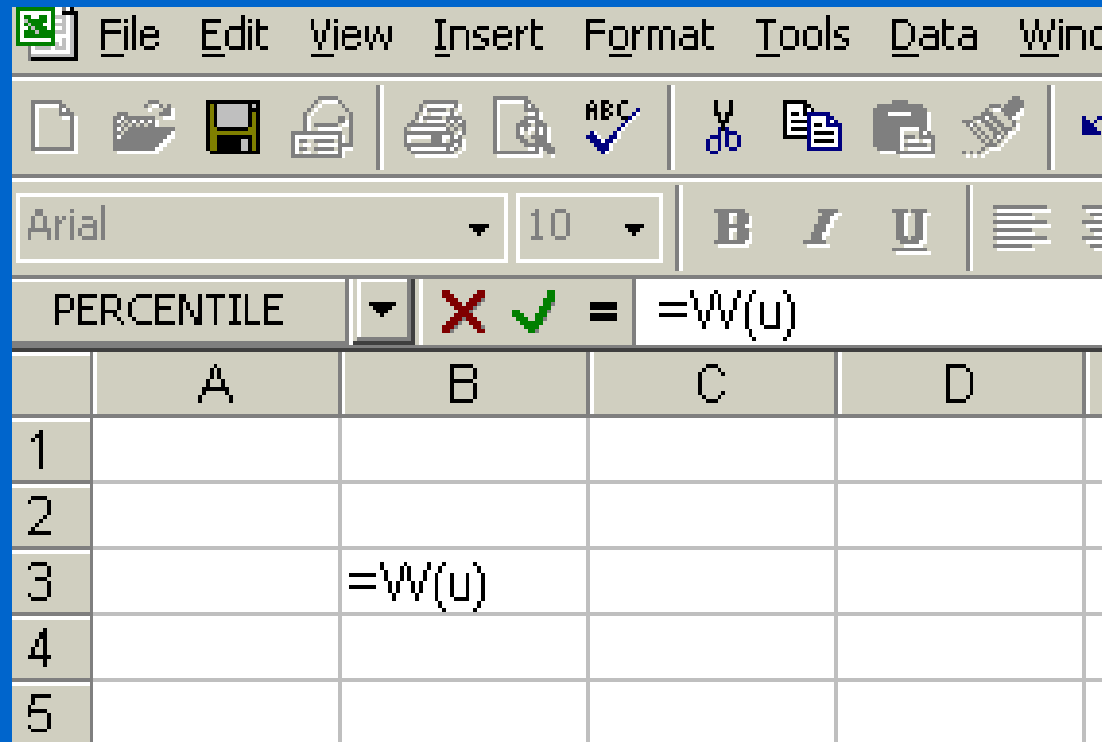

Drawdown due to pumping

Time-drawdown calculations using This equation

Aquifer parameters	
T	1000 m ² /d
S	0.0001
L	
Pumping rate	
q	5 l/s

Radius (m)	4	64	512
Time (days)			
1	0.487	0.296	0.153
3	0.524	0.334	0.191
7	0.553	0.363	0.220
10	0.566	0.375	0.232
20	0.590	0.399	0.256
30	0.604	0.413	0.270
40	0.613	0.423	0.280
50	0.621	0.430	0.287
60	0.627	0.437	0.294
70	0.633	0.442	0.299
80	0.637	0.447	0.304
90	0.641	0.451	0.308
100	0.645	0.454	0.311

Distance-drawdown calculations using This equation

Aquifer parameters	
T	1000 m ² /d
S	0.0001
L	
Pumping rate	
q	5 l/s

Time (days)	1	10	100
Radius (m)			
1	0.582	0.661	0.740
2	0.534	0.613	0.693
4	0.487	0.566	0.645
8	0.439	0.518	0.597
16	0.391	0.470	0.550
32	0.344	0.423	0.502
64	0.296	0.375	0.454
128	0.248	0.327	0.407
256	0.201	0.280	0.359
512	0.153	0.232	0.311
1024	0.106	0.185	0.264
2048	0.061	0.137	0.216
4096	0.023	0.091	0.168

Drawdown vs time

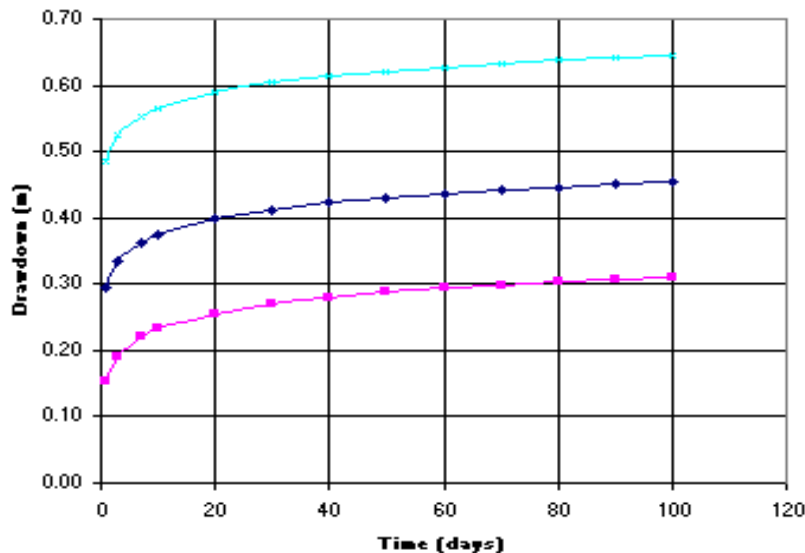

Drawdown vs distance

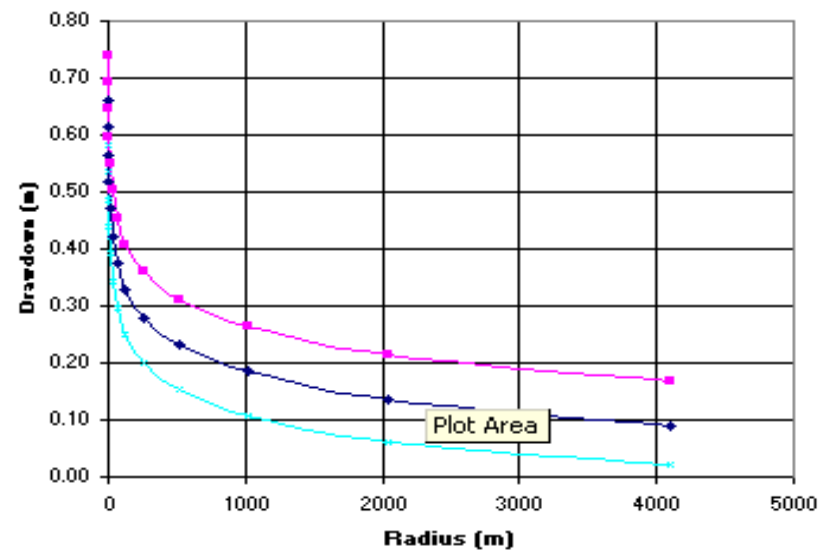

Stream depletion

- Effect of intermittent pumping on an adjacent stream
- Involves another solution derived by Theis
- Uses superposition principle
 - Similar to unit hydrograph method in surface water hydrology
- Look at effects of changing T, S, distance, etc....

Stream depletion

Stream Depletion Analysis

Aquifer parameters

Transmissivity	1000	(m ² /day)
Storage coefficient	0.1	
Separation distance	340	(m)
Streambed conductance		(m/day)
Stream depletion factor	11.6	(days)
Streambed factor		

Pumping details

Maximum rate	21	(l/s)
Hours per day	23	
Days per return period	20	
Return Period	22	(days)
Average rate	18.3	(l/s)
Cut back time	30	(days)
Cut back average rate	0	(l/s)

Stream depletion

Pumping duration	30	(days)
Total depletion	12.1	(l/s)

Only the values in shaded cells can be updated - all other cells are dependent on those input values.
The red curve on the depletion vs time plot shows the net effect of pumping and any specified cut

